



ESIALaska.com

PUMPS

THE HIGH-VOLUME, SELF-PRIMING, MOBILE PUMPING SOLUTION THAT WON'T QUIT.

ES-SP60-ENC FEATURES:

- Sykes CP150 pump-powered by Kubota diesel engine
- 50 CFM vacuum assisted, run-dry priming system
- Alaska designed and built arctic enclosure for reliable year round operation in extreme cold
- 2400 gpm flow rate with 3-inch solids handling
- Durable ESI trailer with built-in fuel tank



Anchorage:

7780 Old Seward Hwy
Anchorage, AK 99518
(907) 341-2250 | (877) 341-2250

Fairbanks:

1919 Van Horn Road
Fairbanks, AK 99701
(907) 458-9049 | (888) 868-9049

Seattle:

17660 W. Valley Hwy
Tukwilla, WA 98188
(425) 251-6119

Williston:

5064 Bennett Loop
Williston, ND 58801
(701) 774-5312

EARTH MOVING | PUMPS | GENERATORS | HEATERS | PARTS

PUMP

- Sykes CP150 series pump
- 6-inch suction and discharge flanges
- Maximum flow rate of 2400 gallons per minute
- 3-inch solids handling capabilities for application flexibility
- Up to 160-foot lift to move liquid to higher discharge points
- Priming system with vacuum assist pump provides run-dry operation
- Automatic self-priming in cases of lost suction
- Heavy-duty construction for reduced maintenance costs
- High efficiency design for reduced fuel costs

WINTERIZED ENGINE

- Kubota V3800T 4-cycle, turbocharged diesel engine
- Maximum shaft power of 95 hp
- DSE control panel for ease of operation and engine speed monitoring
- Optima Spiral Cell technology for superior starting performance

TRAILER

- Temperature controlled enclosure
- Heater duct connection for preheat
- 115 gallon built-in fuel tank
- Rear drop legs for stability during operation
- Front stone guard to protect engine during transport



Specifications

Connections	6" x 6" Class 150 ANSI flanges
Max flow rate	2400 gpm (9000 lpm)
Max solids handling	3" (76 mm)
Max lift	160' (48 meters)
Max operating speed	2200 rpm
Fuel capacity	115 gal (435 L) ULSD
Fuel consumption	4.3 gph @ 2200 rpm (max) 2.9 gph @ 1800 rpm

WATER



CP150i



PRIMAX

Diesel Drive Auto Prime Contractor Pump

The Contractors pump range has been designed to provide greater cost efficient fluid handling solutions for all users.

The range offers efficiency levels of 83% which translate into benefits for the end user and the environment.

Contractors pumps are a fully automatic priming pump and can run dry for extended periods due to the oil bath

mechanical seal assembly which allows priming with long suction hoses and suction lifts of up to 9 metres (28 feet). As fluid levels fluctuate, the pump will “snore” until the liquid is available for the pump to fully reprime itself automatically.

Built with the highest quality materials , 316 SS Impeller and wear plates as standard.

CONTRACTORS RANGE

ALLIGHTPRIMAX

www.allightprimax.com



Features

- Low fuel usage
- Reduced engine sizes
- Lower maintenance costs
- Dry self prime and reprime
- Close coupled SAE Bearing Frames
- Suction lifts to 9m
- Operates in 'snore' conditions
- Vacuum Priming option available for ground dewatering.
- Diesel, electric or hydraulic drive
- Solids handling
- Simple maintenance
- Replaceable wear parts
- Chassis - skid, road tow, wheeled, caged
- Powered by Perkins or Cat Engines.
- Other engines available on request
- Custom build available
- Sykes purpose built Control panel

Application

- Construction
- Environmental
- Industrial
- Mining
- Clean Water
- Sludge
- Slimes
- Sewage
- Solids laden liquids
- Ground Dewatering
- Pipeline & Drilling
- Jetting
- Quarries

Technical Data

MATERIALS OF CONSTRUCTION

Pump Casing:	S.G. IRON 400/12
Suction Cover:	S.G. IRON 400/12
Air Separation Tank:	S.G. IRON 400/12
Bearing Bracket:	S.G. IRON 400/12
Pump Shaft:	431 Stainless Steel
Impeller:	316 Stainless Steel
Wearplates:	316 Stainless Steel
Mechanical Seal:	Silicon Carbide/ Silicon Carbide
N.R.V. (Ball Type):	S.G. IRON 400/12

DESIGN DETAILS

Single Stage, end suction type, 2 vane fully open impeller, Centrifugal pump
 Suction Flange (in/mm): 6/150
 Delivery Flange (in/mm): 6/150
 Solids Handling Size (in/mm): 3/77
 Maximum Head (ft/m): 197/60
 Maximum Capacity: 2726 US gal/min

FUEL USAGE (GAL/HR) @ BEP

Speed (rpm)	POWER USAGE (kW/HP)	FUEL RATE (US gal/hr)	RUN TIME (hrs - 116 US Gal fuel tank)
1400	20/27	1.31	89
1800	38/51	2.48	47
2200	66/88	4.31	27

CALCULATIONS BASED ON 210 g/kw.hr

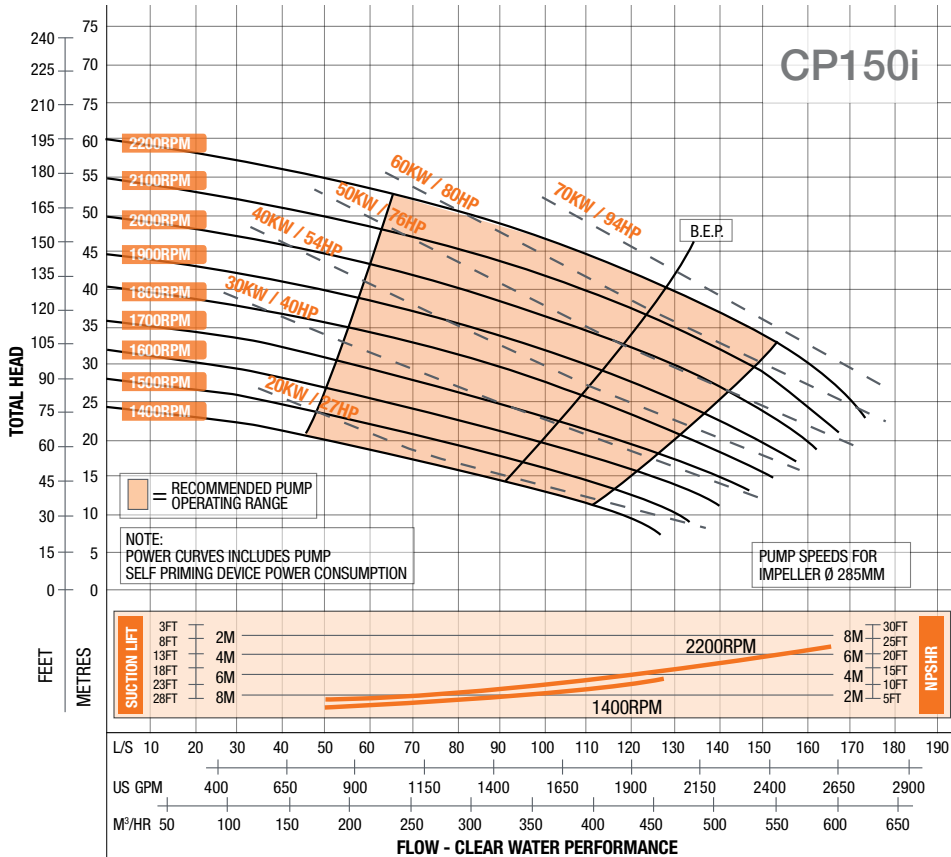

Dry Weight: 1510 lb
 Fuel Capacity: 116 US Gal

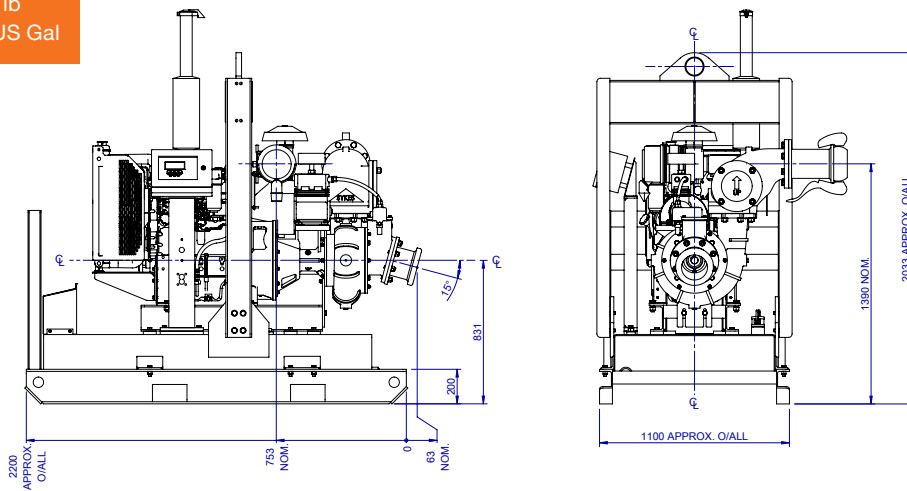

ALLIGHT PRIMAX